

Pressure/Vacuum Relief Valve

deflagration- and endurance burning-proof

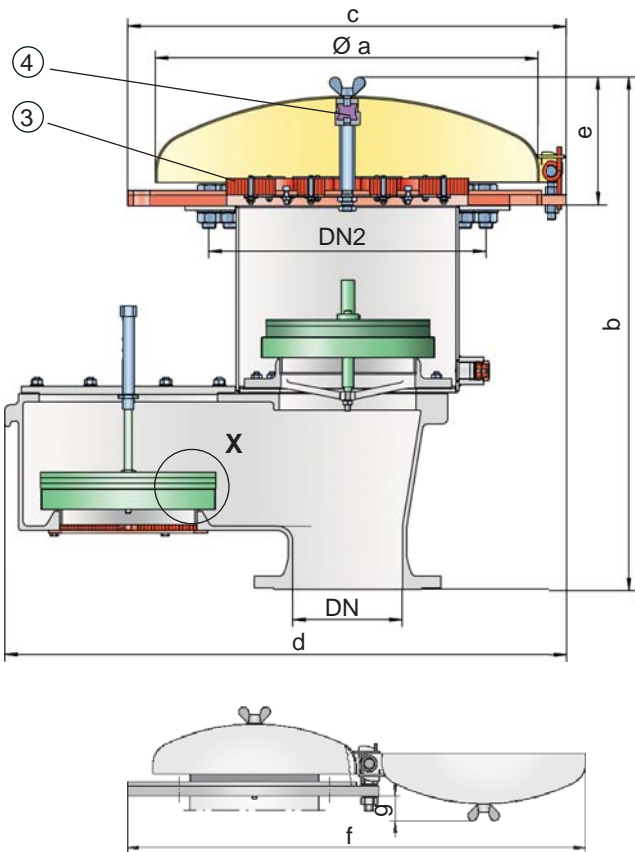

PROTEGO® VD-SV-EB



Detail X

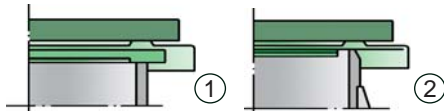

Settings:

pressure:	+2.0 mbar	up to	+60 mbar
	+0.8 inch W.C.	up to	+24 inch W.C.
vacuum:	-2.0 mbar	up to	-60 mbar
	-0.8 inch W.C.	up to	-24 inch W.C.

Higher and lower settings upon request

Function and Description

The deflagration-proof and endurance burning-proof VD-SV-EB type PROTEGO® valve is a highly developed combined pressure/vacuum relief valve for high flow capacities with the integrated flame arrester PROTEGO® EB. It is primarily used as a safety device for flame-transmission-proof in- and outbreathing in tanks, containers and process engineering apparatus. The valve offers reliable protection against excess pressure and vacuum, preventing outbreathing of product vapour and inbreathing of air almost up to the set pressure and also protects against atmospheric deflagration as well as endurance burning if stabilized burning occurs. The PROTEGO® flame arrester unit is designed to achieve minimum pressure drop with maximum safety. The deflagration and endurance burning proof PROTEGO® VD-SV-EB device is available for substances of explosion group IIA (NEC group D MESH > 0.9 mm).

When the set pressure is reached, the valve starts to open and reaches full lift within 10% overpressure. This unique 10% technology enables a set pressure that is only 10% below the maximum allowable working pressure (MAWP) of the tank.

After years of development, this typical opening characteristic of a safety relief valve is now also available for the low pressure range.

The tank pressure is maintained up to the set pressure with a tightness that is far superior to the conventional standard due to our state of the art manufacturing technology. This feature is ensured by the valve seats made of high quality stainless steel and with individually lapped valve pallets (1) or with an air cushion seal (2) in conjunction with a high quality FEP diaphragm. The valve pallets are also available with a PTFE seal to prevent the valve pallets from sticking when sticky products are used and to enable the use in corrosive fluids. After the excess pressure is discharged, the valve reseats and provides a tight seal.

If the set pressure is exceeded, explosive gas/product-vapour air mixtures are released to the atmosphere. If this mixture ignites, the integrated flame arrester PROTEGO® EB (3) prevents flame transmission into the tank. If additional mixture continues to flow and stabilized burning occurs, the integrated flame arrester unit prevents flashback as a result from endurance burning. The valve is protected and also fulfils its function under this severe service conditions. The spring loaded weather hood opens as soon as the fusible element (4) melts.

The valve can be used up to an operating temperature of +60°C / 140°F and meets the requirements of European tank design standard EN 14015 – Appendix L and ISO 28300 (API 2000).

Type-approved in accordance with the current ATEX Directive and EN ISO 16852 as well as other international standards.

Special Features and Advantages

- requires only 10% overpressure to full lift for explosion group IIA (NEC group D) vapours
- through 10% technology higher set pressures can be used which results in product loss reduction compared to conventional 40% and 100% overpressure technology vents (compare API 2000)
- more design flexibility through higher reseating pressures; vents reseat when conventional vent is still discharging costly product or nitrogen
- the valve disc is guided within the housing to protect against harsh weather conditions
- high performance seal reducing product loss below EPA's 500ppm rule preventing environmental pollution
- can be used as protective system according to ATEX in areas subject to explosion hazards
- safe against deflagration and endurance burning for explosion group IIA (NEC group D) vapours
- high flow capacity through large FLAMEFILTER® cross-section, results in low pressure drop
- FLAMEFILTER® provides protection against atmospheric deflagration and endurance burning
- FLAMEFILTER® integrated into the valve saves space, weight and reduces cost
- FLAMEFILTER® protected from clogging caused by product vapours
- flame transmission proof condensate drain
- maintenance friendly design
- modular design enables individual FLAMEFILTERS® and valve pallets to be replaced



Vents - 10% Technology
(Flyer pdf)



Leak Rate/10% Technology
(Flyer pdf)



Demonstration of endurance burning
Video

Design and Specifications

Any combination of vacuum and pressure levels can be set for the valve.
The valve discs are weight-loaded.

Pressure/vacuum relief valve, basic design **VD-SV-EB** -

Pressure/vacuum relief valve, with heating jacket **VD-SV-EB** -

Additional special devices available upon request

Table 1: Dimensions

Dimensions in mm / inches

DN	DN2	a	b	c	d	e	f	g
150 / 6"	400 / 16"	705 / 27.76	844 / 33.23	802 / 31.57	957 / 37.68	235 / 9.25	1500 / 59.06	109 / 4.29
200 / 8"	400 / 16"	705 / 27.76	939 / 36.97	802 / 31.57	1027 / 40.43	235 / 9.25	1500 / 59.06	109 / 4.29

Table 2: Selection of explosion group

MESG	Expl. Gr. (IEC/CEN)	Gas Group (NEC)	Special approvals upon request
> 0,90 mm	IIA	D	

Table 3: Material selection for housing

Design	A	B	Special materials upon request
Housing	Steel	Stainless Steel	
Heating jacket (VD-SV-EB-H-...)	Steel	Stainless Steel	
Valve seats	Stainless Steel	Stainless Steel	
Gasket	PTFE	PTFE	
Flange ring	Steel	Stainless Steel	
Weather hood	Steel	Stainless Steel	
Flame arrester unit	A	A, B	

Table 4: Material combination of flame arrester unit

Design	A	B	Special materials upon request
FLAMEFILTER® cage	Steel	Stainless Steel	
FLAMEFILTER®	Stainless Steel	Stainless Steel	
Safety bar	Stainless Steel	Stainless Steel	

Table 5: Material selection for pressure valve pallet

Design	A	B	C	D	E	F
Pressure range (mbar) (inch W.C.)	+2.0 up to +3.5 +0.8 up to +1.4	>+3.5 up to +14 >+1.4 up to +5.6	>+14 up to +35 >+5.6 up to +14	>+35 up to +60 >+14 up to +24	>+14 up to +35 >+5.6 up to +14	>+35 up to +60 >+14 up to +24
Valve pallet	Aluminium	Stainless Steel	Stainless Steel	Stainless Steel	Stainless Steel	Stainless Steel
Sealing	FEP	FEP	Metal to Metal	Metal to Metal	PTFE	PTFE

Special material as well as higher set pressure upon request

Table 6: Material selection for vacuum valve pallet

Design	A	B	C	D	E	F
Vacuum range (mbar) (inch W.C.)	-2.0 up to -3.5 -0.8 up to -1.4	<-3.5 up to -14 <-1.4 up to -5.6	<-14 up to -35 <-5.6 up to -14	<-14 up to -35 <-5.6 up to -14	<-35 up to -60 <-14 up to -24	<-35 up to -60 <-14 up to -24
Valve pallet	Aluminium	Stainless Steel	Stainless Steel	Stainless Steel	Stainless Steel	Stainless Steel
Sealing	FEP	FEP	Metal to Metal	PTFE	Metal to Metal	PTFE

Special material as well as higher set vacuum upon request

Table 7: Flange connection type

EN 1092-1; Form B1	other types upon request
ASME B16.5; 150 lbs RFSF	



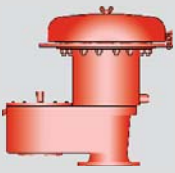

Pressure/Vacuum Relief Valve

Flow Capacity Charts

PROTEGO® VD-SV-EB-IIA

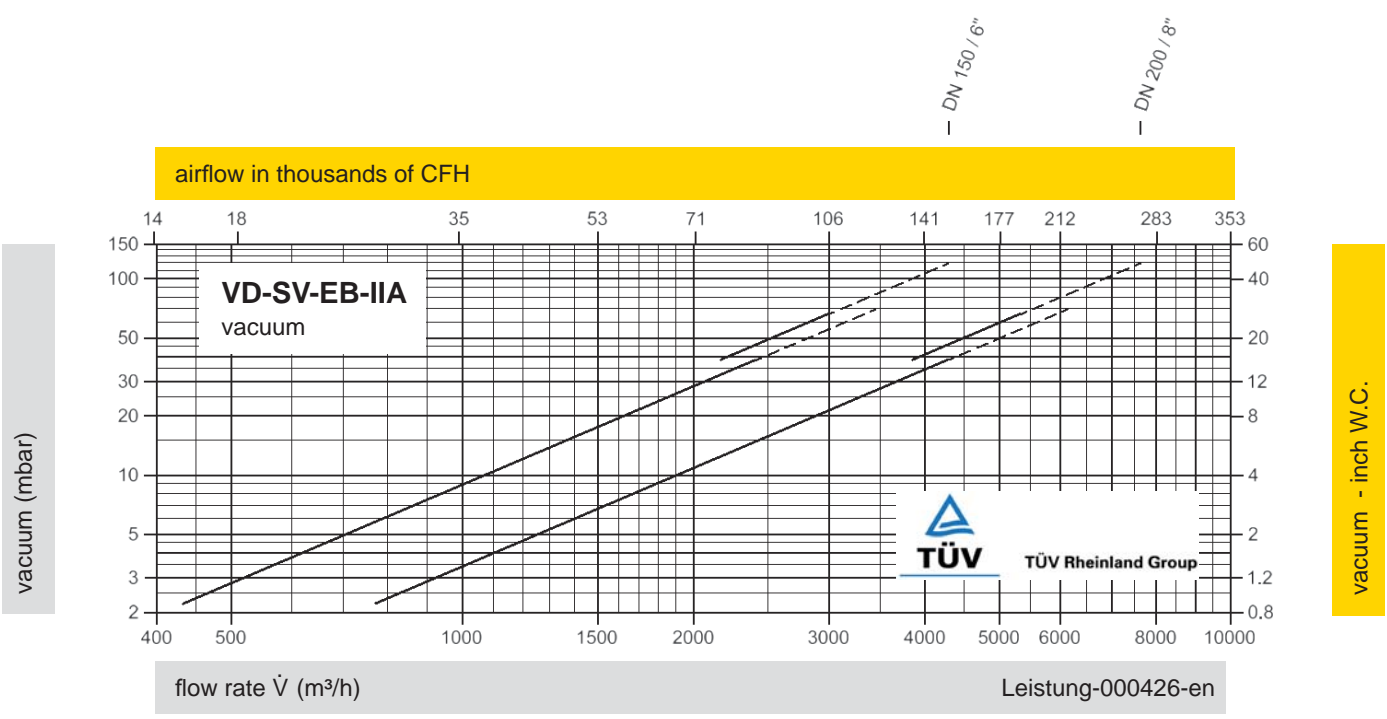
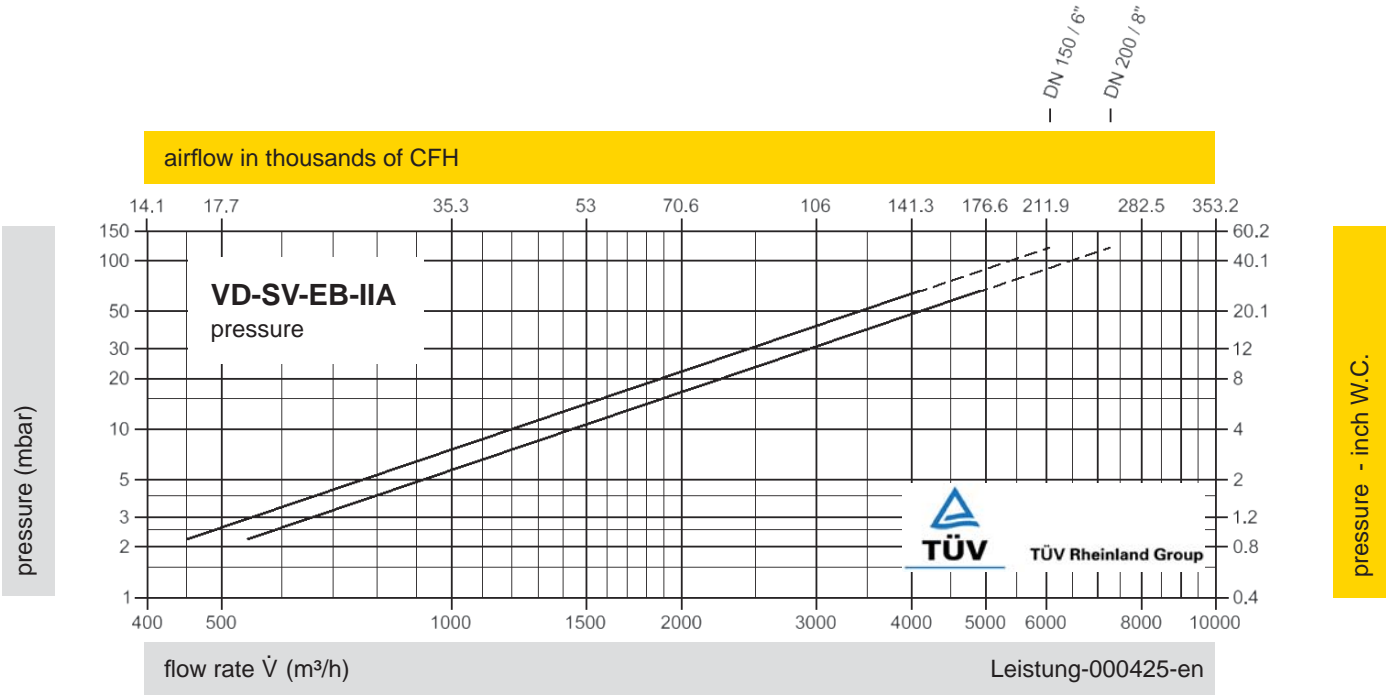

The flow capacity charts have been determined with a calibrated and TÜV certified flow capacity test rig. Volume flow \dot{V} in (m³/h) and CFH refer to the standard reference conditions of air ISO 6358 (20°C, 1bar). Conversion to other densities and temperatures refer to Vol. 1: "Technical Fundamentals".